

Technical Service Bulletin 49  
 S22 Tracking Fin Installation  
 January 11, 2001

This bulletin outlines the installation procedure for a tracking fin on an S22. This is an optional add-on that a customer may wish to add to their boat to decrease lateral movement when towing a skier.

**Parts Needed**

Optional Tracking Fin #MSP0010189	4 #14 X 1 1/4" SS phillips flat SMS
-----------------------------------	-------------------------------------

**Tools Needed**

Drill w/ 1/2" chuck and key	5/32" Drill bit w/drill stop	Caulk gun
#4 Phillips screwdriver	9mm wrench	

**⚠ WARNING**

Always be sure to wear OSHA approved eye protection when using a drill or other rotary tools as these have the potential to throw debris into the air.

**Procedure**

**Step 1 – Remove Floor Panels**

First, unsnap the aft-center seat cushion and the aft center seat back. Store these somewhere outside the boat to protect the vinyl during campaign work. Remove the aft-center seat base by removing the v-drive access cover and unbolting the two nylon nuts, using a 9mm wrench, holding the seat base to the deck. Next, remove all three of the carpeted floor panel to expose the fuel tanks, bilge and exhaust. Finally, remove the bilge divider between the fuel tank and the exhaust system.



## Step 2 – Empty Fuel Tank



**CAUTION:** Gasoline vapors are highly flammable. Campaign work must be done in a highly ventilated area well away from any potential source of spark or flame.

Before beginning to remove the fuel tank hosing or retaining brackets, all fuel must be removed from the fuel tank using a gasoline approved pump and stored in an EPA and DOT approved container during Campaign work. **NOTE: It is important to remove all the fuel before attempting to remove fuel tank from the boat. Fuel tank weighs over 250lbs when full and is not structurally designed for lifting while full of fuel.**

## Step 3 – Remove Fuel Tank

To remove the fuel tank you must first unscrew the four retaining brackets from the decking and remove the forward, starboard bracket from the fuel tank. The forward, starboard bracket must be removed to prevent possible damage to the driver's seat upholstery when the tank is lifted from the bilge. Next, cut the tie wraps holding the fuel sensor wire to the tank and disconnect the fuel sensor wire at the connector by the aft end of the fuel tank. Disconnect all four fuel hoses by loosening the hose clamps and removing hoses. Finally, to remove the fuel tank from the bilge it must be slid back towards the engine and lifted out of the bilge by the aft end of the fuel tank. Care must be taken to prevent residual fuel from dripping out of the forward fuel hose location onto the interior of the boat.

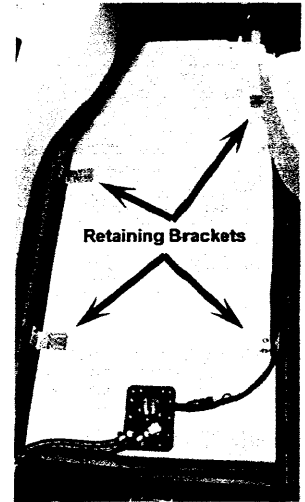

## Step 3 – Positioning the tracking fin

Locate centerline on bottom of hull. Place fin inside of indentation making sure that the flatter side is facing toward the bow as shown below, and mark four drilling holes using the base of the fin as a template. Finally, place fin off to the side.

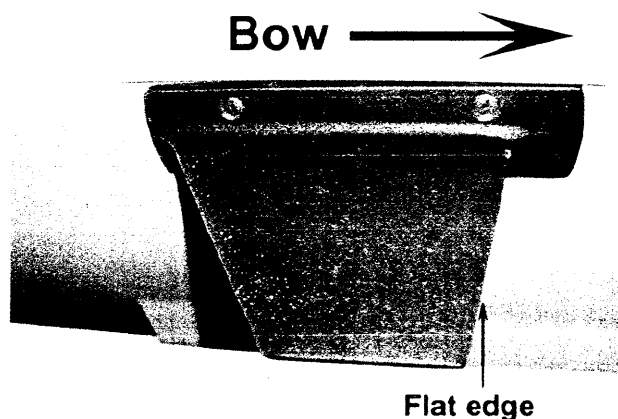

#### Step 4 – Drilling holes

Install power drill alignment adapter and drill stop at 1 1/4" depth. Drill four holes into the hull from underneath the hull using a 5/32" drill bit. Finally, apply a liberal amount of silicone to and around the holes drilled into the hull. **NOTE:** It is essential to maintain this drill depth as excessive depth can result in puncturing the liner.



#### Step 5 – Install fin

First, apply a light coat of silicone to the tracking fin base on the hull side. Next, apply a coating of silicone to four #14 x 1 1/4" SS flat head phillips SMS screws. Finally, install screws into tracking fin base holes.



#### Step 6 – Replacing fuel tank

Reverse steps 1 through 3 to replace and refill the fuel tank.