



Technical Service Bulletin 29

Revision #1

Bimini Top - Windshield Mount

March 14, 2000- Rev Inv. April 30 , 2003

Bimini Top, E22, Blue – MBCZ822021
 Bimini Top, E22, Claret – MBCZ822023
 Bimini Top, E22, Teal – MBCZ822025

Bimini Top, E22, Green – MBCZ822022
 Bimini, E22, Grey – MBCZ822024-NLA
 Bimini, E22, Red – MBCZ822026-NLA

Parts Needed

Windshield Mounting Hardware – MBC0011193

Hardware Kit Includes

4 Thumbscrew brackets	8 Screws	4 Thumbscrews
-----------------------	----------	---------------

Tools Needed

Tape Measure	Drill	5/32 nd Drill bit
Grease pen	Screwdriver	

⚠ WARNING

Always be sure to wear OSHA approved eye protection when using a drill or other rotary tools as these have the potential to throw debris into the air.

Procedure

Step 1 – Positioning Bottom Brackets

On the starboard side, measure up the inside of the windshield frame from its base and mark at 14". Next, use the black thumbscrew brackets included in the hardware kit and the mark you just made to find the final position for the bottom bracket's mounting screws. Mark these locations with a grease pen. Repeat this step on the port side.

Step 2 – Positioning Top Brackets

On the starboard side, measure up the inside of the windshield frame from its base and mark lines at 30". Next, use the black thumbscrew brackets included in the hardware kit and the mark you just made to find the final position for the top bracket's screws. The screw holes must face straight outward to allow for easy thumbscrew installation. Mark these locations with a grease pen. Repeat this step on the port side.

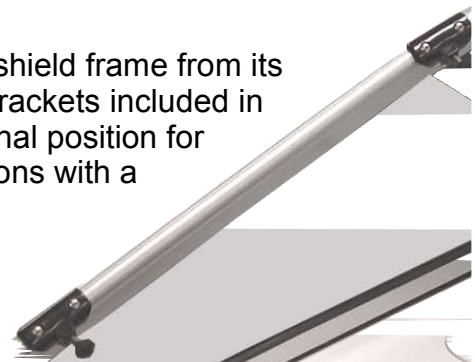

Step 3 – Drill Screw Holes

Using a 5/32nd drill bit carefully drill out the pilot holes for the top and bottom brackets on both the port and starboard side of the windshield. **Note: Care must be taken to avoid drilling out the far side of the windshield frame.**

Step 4 – Install the Brackets

Using the eight 1/2" screws included in the hardware kit, install the four thumbscrew brackets on the windshield. **Note: Do not use a motorized screwdriver.**

Step 5 – Installing The Canvas Top

The canvas top and support arms comes preassembled and just needs to be attached to the windshield thumbscrew brackets.

First, attach the main arm of the cover bottom set of brackets using the thumbscrews included in the cover kit. The main support arm should point towards the aft when the cover is unfolded. The zipper on the top should be on the aft end when the cover is unfolded.

Next, attach the shorter support arms to the forward set of thumbscrew brackets. After the forward support arms are attached extend the cross arm support from the forward arm and connect it to the empty bracket on the main support using the pins attached to the cross arm support. Finally, extend the cross arm until it is fully extended and the spring loaded ball locks into the drilled hole in the arm. It may be necessary to reposition the arms slightly to tighten the canvas top properly. The support arm brackets can be adjusted by loosening the set screw located on the back of each bracket.

